

7" HEAVY DUTY WIRELESS CAMERA KIT



SKU:D-KIT-0016

The 7" Heavy Duty Wireless Camera Kit provides reliable HD rear-view monitoring for commercial vehicles, plant machinery, trailers, horseboxes, and motorhomes. Featuring a 7" IPS widescreen monitor, IP69K waterproof 1080P camera, and up to 200m wireless transmission range, it delivers clear and stable video in demanding environments. Designed for easy installation with DC12–24V compatibility, low power consumption, and built-in circuit protection.



PRODUCT SPECIFICATION

MONITOR

Screen Ratio	16:9 IPS panel
Resolution	1024 × RGB × 600
Backlight	LED, 500 cd/m ²
Viewing Angle	Horizontal: Left 85° / Right 85° Vertical: Up 85° / Down 85°
Working Temperature	-20°C to +70°C (85% RH Max)
Storage Temperature	-30°C to +85°C (95% RH Max)
Power Supply	DC 12-24V
Audio	Built-in
Delay Time	120mS
Electric Current	Standby: ≤10mA / Working: ≤110mA
Power Consumption	<3W
AV Input	1-4 channel HD wireless video signal input
Operating Frequency Range	2400 - 2483.5MHz
System	PAL/NTSC automatically
Decompression Mode	H.264
Receive Sensitivity	-89dBm@4MHZ
Spread Spectrum Mode	FHSS(Adaptive frequency hopping)
Transmission Distance	200m in open area
Shockproof Level	4G
Power Cable	DC Cable

PRODUCT SPECIFICATION

CAMERA

Image Sensor	CMOS 1/2.7"
Resolution	1080P (1920 × 1080 Pixels)
Operating Frequency Range	2400-2483.5MHZ
Transmission Distance	Up to 200m in Open Areas
Video System	PAL/NTSC automatically
Spread Spectrum Mode	FHSS (Adaptive frequency hopping)
Transmission Bandwidth	8MHz BER <1E-3
Working Temperature	-20°C to +70°C (85% RH Max)
Storage Temperature	-30°C to +85°C (95% RH Max)
Audio	Built-in
SNR	46.5dB
Waterproof	IP69K
Viewing Angle	120° Diagonal Viewing Angle
Transmitting Sensitivity	-89 dBm
Housing Material	Black Aluminium Alloy

PRODUCT DIMENSIONS

MONITOR DIMENSIONS

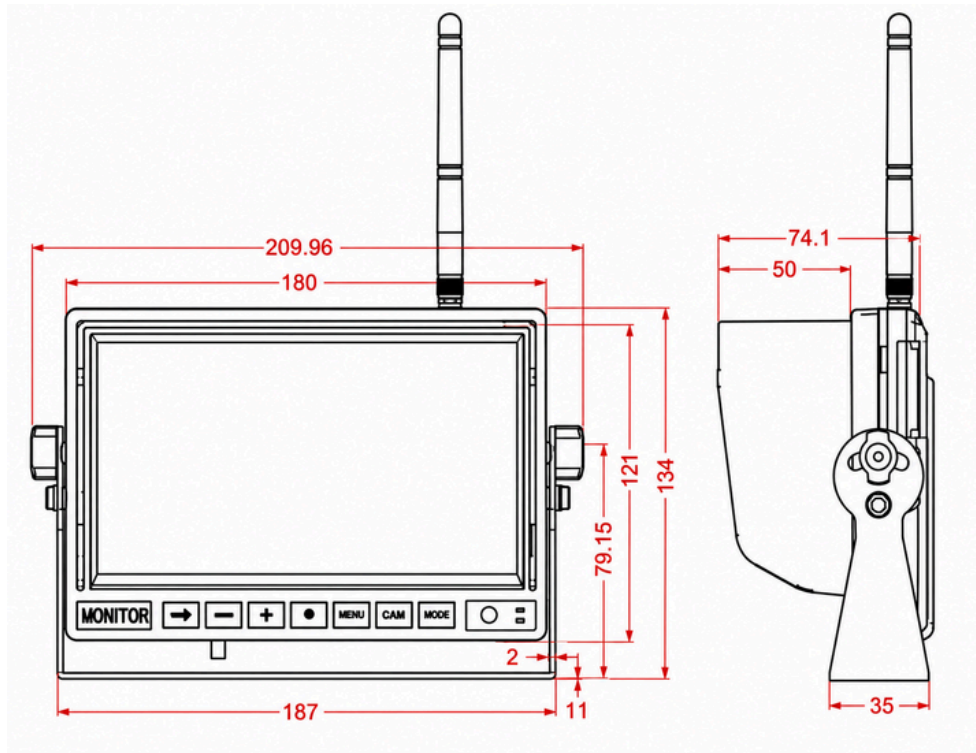

CAMERA DIMENSIONS

